

BOIP



Benelux Office for  
**Intellectual  
Property**

[www.boip.int](http://www.boip.int)



# Masterclass merkenrecht: Acceptatie en weigering van merken

1 juni 2023 – Yvonne Noorlander

WIFI: BOIP GUEST / 1750772558





# Programma

---

13.05 – 14.30    Acceptatie en weigering  
merken  
*(theorie)*



---

14.30 – 15.00    Koffie-/theepauze



---

15.00 – 16:00    Committee of legal officers  
*(praktijk)*

---



BOIP



Benelux Office for  
Intellectual  
Property

# CONGRATULATIONS

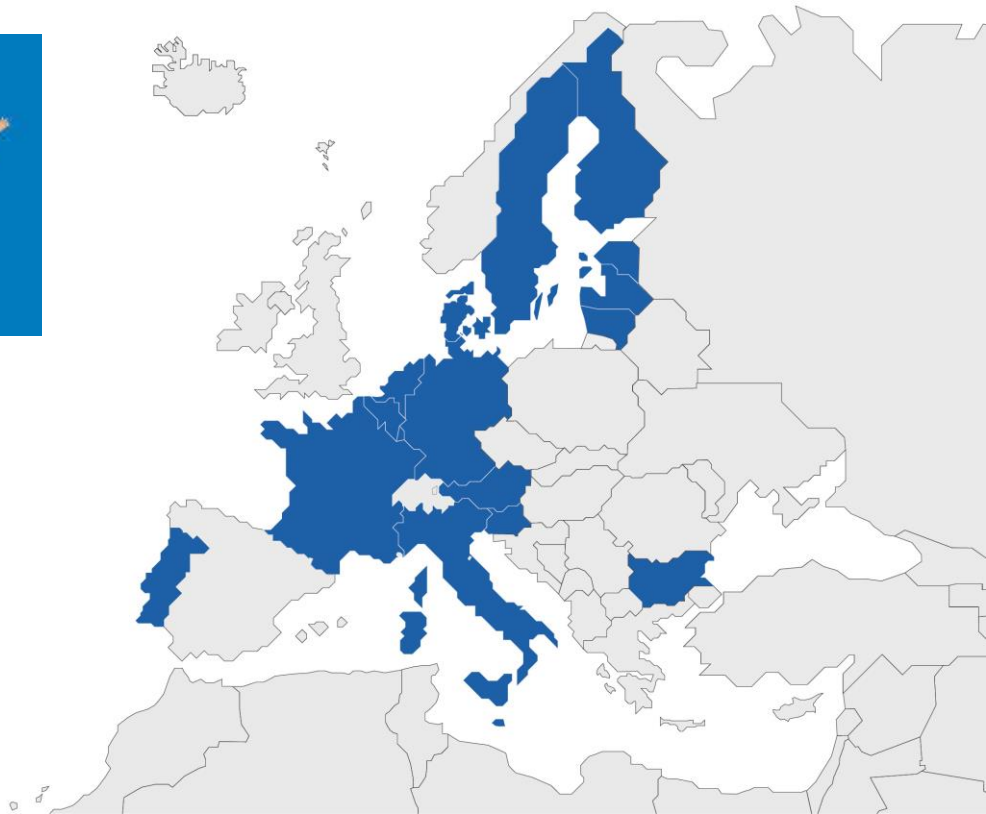

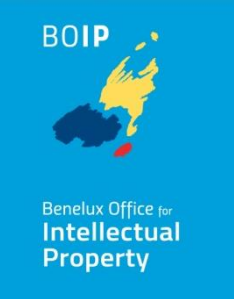

# Introductie BOIP

- ❖ BMW 1971
- ❖ Gevestigd in Den Haag
- ❖ +/- 85 medewerkers
- ❖ Werktaal NL/FR/EN
- ❖ 100% self-supporting



Office Benelux de la Propriété intellectuelle  
Benelux-Bureau voor de Intellectuele Eigendom  
Benelux Office for Intellectual Property



BOIP



Benelux Office for  
Intellectual  
Property

# Introductie



Hogeschool  
van Amsterdam



Universiteit  
Leiden



"Some people call me a lawyer, the most important call me mommy,,





# Relevantie



Merk: woord, beeld etc.

Octrooi: techniek

Model: vormgeving

Overig: auteursrecht, slaafse nabootsing etc.

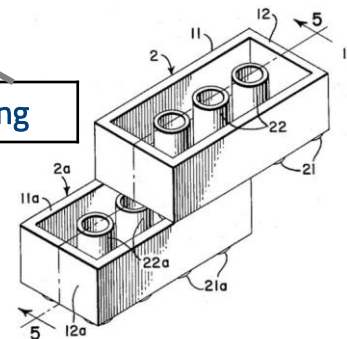



# Merktypes

- Woordmerk
- Beeldmerk
- Vormmerk (3D merk)
- Kleurmerk
- Klankmerk
- Patroonmerk
- Positiemerk
- Bewegingsmerk
- Multimediamerk
- Hologrammerk



APPLE

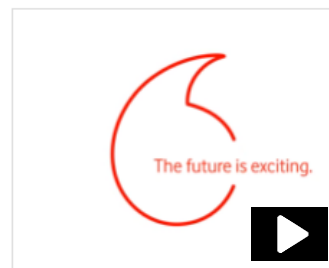
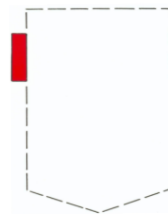
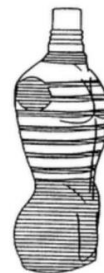



## Formele vereisten

1. **Naam en adres van de deposant: Indien onderneming - rechtsvorm;**
2. Indien gemachtigde: naam en adres van de gemachtigde;
3. **Het merk;**
4. De waren en diensten;
5. **Het type merk;**
6. Indien kleurmerk: vermelding van kleur of kleuren in woorden (Indien van toepassing kleurcode);
7. Indien prioriteit eerder depot: gegevens van het depot en een bewijs bijgevoegd;
8. Indien onderscheidende elementen: een duidelijke omschrijving hiervan;
9. De handtekening van de deposant of de gemachtigde.







# Proces merkaanvraag

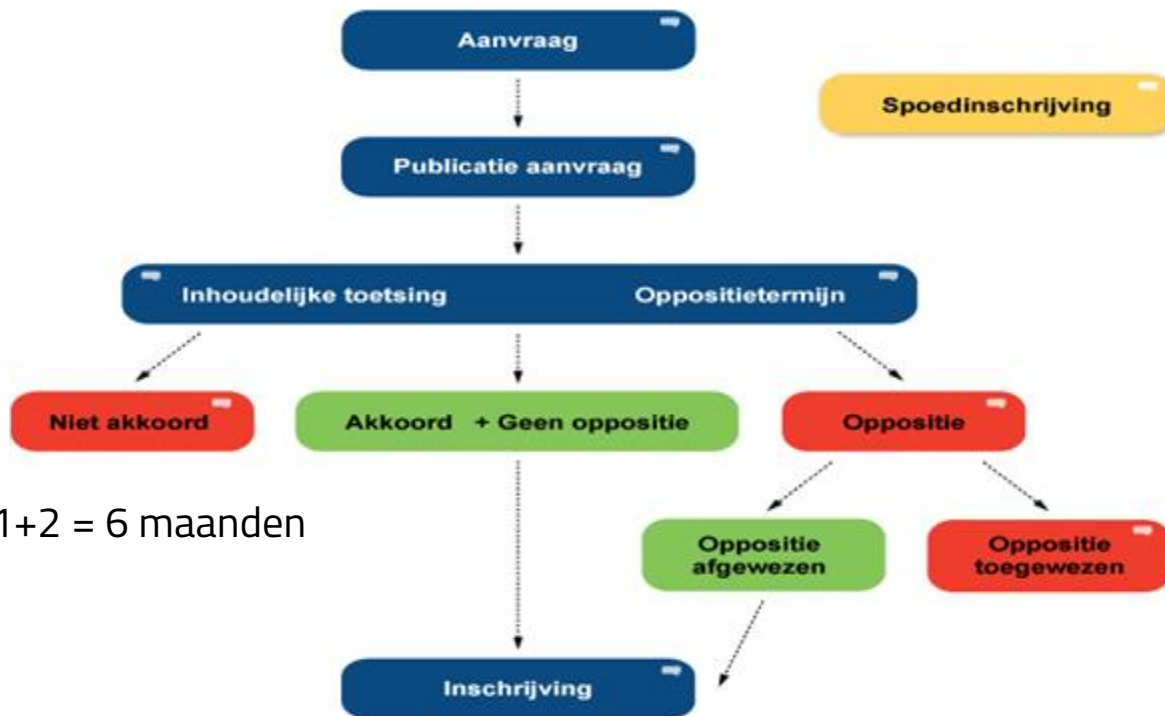



## Achter de schermen



- Operations - onderzoekers
- Legal



- Herlezen Legal Officers
  - \*(Acceptaties)
  - \*Weigeringen



- Committee of Legal Officers (CoL)
  - \*Twijfelgevallen merkaanvragen
  - \*Bezwaarschriften

Verdeling bezwaarschriften: beschikbaarheid, taal.





## Werkwijze

Basis:

- BVIE;
- UR;
- Richtlijnen;
- CP's;
- Regels DG;
- Rechtspraak.



**Toetsing zo feitelijk en concreet mogelijk -**

Benadering die overeenstemt met economische realiteit

- Algemene kennis
- Internet;
- Woordenboeken;
- Eerdere weigeringen;
- Tools (E-ambrosia, GI-view, CPVO, 6ter database WIPO).





## Absolute weigeringsgronden 1/5

2.2bis lid 1	Wat?	Waarom?	Voorbeeld
a.	Geen merk in de zin van art. 2.1 BVIE	Markttransparantie en rechtszekerheid	
b.	Onderscheidend vermogen	Markttransparantie	I LOVE YOU voor sieraden ----- VDTje - TIME VLAAI'S WHEN YOUR HAVING FUN
c.	Beschrijvende merken	Concurrentiebelang en algemeen belang	Niet: XXL Gym, BioPetFood Wel: 
d.	Gebruikelijk geworden (verwaterd)	Concurrentiebelang en algemeen belang	RANJA voor limonadesiroop





## Absolute weigeringsgronden 2/5

2.2bis lid 1	Wat?	Waarom?	Voorbeeld
e.	Vormen en kenmerken van waren uitgesloten (vorm-exceptie)	Mededinging en scheiding tussen IE regimes	
i.	Aard	Mededinging/ vrijhouding basisvormen	 
ii.	Technische uitkomst (techniek-exceptie)	Technische innovatie/ Octrooi	
iii.	Wezenlijke waarde	Esthetische innovatie/ Model- en auteursrecht	







## Absolute weigeringsgronden 3/5

2.2bis lid 1	Wat?	Waarom?	Voorbeeld
f.	Strijd met openbare orde (1) of goede zeden (2)	Algemeen belang	JODEN voor douchekranen
g.	Misleiding	Consumentenbelang	Aanduiding die niet strookt met inhoud: donuts voor koffie 
h.	6ter UvP: bescherming van officiële symbolen	Consumentenbelang (misleiding)	Gebruik officiële symbolen zonder toestemming 





## Absolute weigeringsgronden 4/5

2.2bis lid 1	Wat?	Waarom?	Voorbeeld
i.  	Beschermd geografische aanduiding (BGA) of oorsprongsbenaming (BOB)	Consumenten- en producentenbelang	BGA of BOB in merk, dan waren 'conform de specificaties van de BGA of BOB'
j.	Traditionele aanduidingen voor wijn (TAW)	Consumenten- en producentenbelang	TAW in merk, dan waren 'conform specificaties van de TAW'
k. 	Gegarandeerde traditionele specialiteiten (GTS)	Consumenten- en producentenbelang	GTS in merk, dan waren 'conform de specificaties van de GTS'





## Absolute weigeringsgronden 5/5

2.2bis lid 1	Wat?	Waarom?	Voorbeeld
I.	Plantenrasbenaming (PRB) voor identiek of aanverwant ras	Markttransparantie	Als PRB bestaat, dan merk uitzonderen voor dat ras (bijv. planten, m.u.v. rozenplanten)
2.2bis lid 3	Inburgering - alleen voor sub b., c. en d. !	Markttransparantie: Herkomstfunctie wordt daadwerkelijk vervuld in de praktijk	Booking.com







## Beschrijvende tekens

- Woorden
- Woordcombinaties
- Zinnen
- Letters
- Cijfers
- Beelden

Chillpants

Wave to pay

24/7

Brussels Kizomba Festival

kg



C

LUX

Flat tummy tea

BOIP



Benelux Office for  
Intellectual  
Property

Oefening



Koekkoek



## Nu is de beurt aan jullie



*"Son, I've taught you everything I know. Now it's up to you."*

CIN  
COLLECTION





# STUDIO SUEDE

KI 35 Reclame; marketing.

KI 41 Productie van films.

KI 42 Diensten op het gebied van grafische ontwerpen.





# COV-ER



KI 10 Gezichtsmaskers (Beschermd -) voor medisch gebruik.



BOIP



Benelux Office for  
Intellectual  
Property



Kl 33 Wijnen.

BOIP



Benelux Office for  
Intellectual  
Property



KI 32 Bier.

KI 33 Alcoholische dranken.



**WE DREAM BIG TO CREATE  
A FUTURE WITH  
MORE CHEERS**



KI 12 Ambulances.

KI 39 Ambulancevervoer; Ambulancediensten; Ambulance-vervoer; Vervoer per ambulance; Vervoer van patiënten met ambulances.

KI 44 Medische hulpverlening; Medische hulpverlening bij spoedgevallen.







# WinkIn

KI 35 Detailhandeldiensten op het gebied van kleding.

KI 38 Telecommunicatie (internettoegang).

KI 42 Webhosting.



BOIP



Benelux Office for  
Intellectual  
Property



KI 35 Detailhandeldiensten op het gebied van kleding.

KI 38 Telecommunicatie (internettoegang).

KI 42 Webhosting.





KI 5 Dieetvoedingsmiddelen voor medisch gebruik; Dieetsupplementen voor mensen; Dieetsupplementen in de vorm van dranken.

BOIP



Benelux Office for  
Intellectual  
Property

# love2smile



KI 3 Strips voor het wit maken van tanden.





# Balkanbio®



KI 1 Probiotische bacterieculturen voor de levensmiddelenindustrie.

KI 5 Voedingssupplementen.

KI 30 Thee en kruidenthee.



BOIP



Benelux Office for  
Intellectual  
Property



# SOLEMATES

KI 25 Pantoffels.



**РУССКИЙ ВОЕННЫЙ КОРАБЛЬ, ИДИ НА\*\*Й**

**RUSSIAN WARSHIP, GO F\*\*K YOURSELF**



KI 9 Apparaten voor het navigeren, gidsen, volgen, plaatsbepalen en het maken van kaarten.

KI 14 Sierraden.

KI 25 Kleding.

KI 41 Educatie.



BOIP



Benelux Office for  
**Intellectual  
Property**

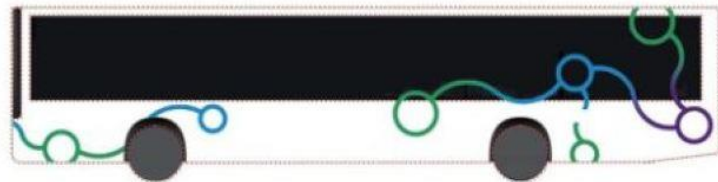

KI 39 Transportdiensten.





# Antwerp First

KI 25 Kleding; T-shirts; football jerseys.

KI 28 Voetballen; tennis rackets.

KI 41 Organisatie van voetbalwedstrijden.

KI 45 Lobbyen voor politieke doeleinden; organisatie van politieke bijeenkomsten.



BOIP



Benelux Office for  
Intellectual  
Property

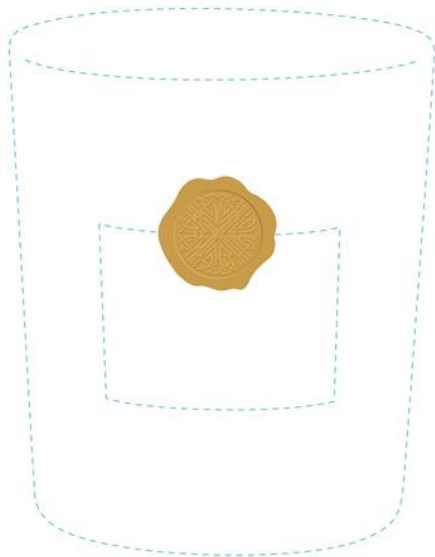

KI 4 Kaarsen.

BOIP



Benelux Office for  
Intellectual  
Property





## Tips and tricks

-Informatiecentrum: 070-3491242 / contact formulier boip.int / info@boip.int

-Waren- en dienstenomschrijving specifiek;



Merk: LAKEVIEW

Klasse 36: Niet: Onroerend-goed zaken.

Wel: Pensioenfonds (investeert in onroerend-goed).



Merk:



Klasse 30: Koffie; thee; koekjes; donut mix; donuts.

-Inburgeringsmateriaal bij indiening;

**Booking.com**



-Kwaliteit boven kwantiteit.

BOIP



Benelux Office for  
**Intellectual  
Property**

[www.boip.int](http://www.boip.int)

Trademarks  
**Intellectual** Patents  
**Property** Designs  
Copyright Ideas



MERCI, BEDANKT, THANK YOU!

Vragen?

Yvonne Noorlander ([ynoorlander@boip.nl](mailto:ynoorlander@boip.nl))

